



TECHNICAL SPECIFICATIONS

Racks/hour (theoretical)	20/10/7
Cycle time *1	180/360/540/720 sec
Power supply	415V, 3Ø+N 50Hz
Wash pump	2 x 2.7kW
Booster heater	9kW
Wash tank heater	9kW
Total power	14.5kW
Total current	3 x 20Amp
Wash tank capacity	100ltrs
Booster heater capacity	15ltrs
Water consumption (per cycle)	8ltrs
Min/max water pressure *2	200/600kPa
Min/max water temp *3	50/65°C
Rack size	1350 x 725mm
Useful height	820mm
Max dish height	820mm
Weight (empty)	320kg
Weight (shipping)	425kg
Dimensions (shipping)	1700Lx1050Wx2050H
Drain type	Gravity (min 3ltr/sec)
Water connection	R3/4" hose
Required hot water supply	120 ltr/hr
Drain hose diameter	30mm
Rinse aid dispenser	Standard
Detergent dispenser	Included

*1 All Machines fitted with thermostop which may effect cycle time

*2 Optional booster pump is available if the water pressure is below 200kPa; reducer required if over 600kPa

*3 Minimum incoming water temperature without loss of performance; units can operate with cold water at reduced performance. (Optional 8kW cold water booster heater)

Machine must be connected according to local regulations.

STANDARD FEATURES

- Double skinned construction
- Deep-formed tank
- Independant stainless steel wash & rinse arms
- Double tank filter with debris collection system & pump filter
- Self cleaning vertical pump
- Standard rinse pump
- Electronic controls
- Four washing cycles
- Energy saving
- Thermostop to guarantee the rinse temperature to HACCP requirements
- Multichromatic start key
- Optional heat recovery



The LP4-S8 Plus is Rhima's most powerful front loading pot and utensil washer. The LP4-S8 Plus is the same size as two LP1-S8 Plus put together. All LPs have the same programming and finish, which means larger operations can use different sized machines, all with the same operating features.

TECHNICAL DRAWING

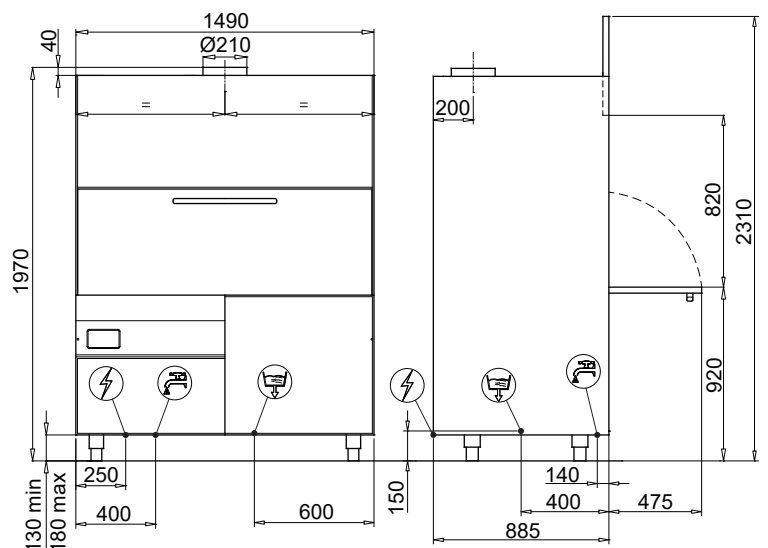

All details subject to change without notice



WaterMark
WMTS101:2018
WM-022203

Call Rhima Australia
today on **1300 347 944**

